

8484A POWER SENSOR



POWER SENSOR 8484A

SERIAL NUMBERS

This manual applies directly to instruments with serial numbers prefixed 2237A.

With the changes described in the Appendix this manual also applies to instruments with serial numbers prefixed 1528A, 1635A, 1916A, and 2046A.

For additional important information about serial numbers, see paragraph on INSTRUMENTS COVERED BY MANUAL.



© HEWLETT-PACKARD COMPANY 1975, 1978, 1980
1501 PAGE MILL ROAD, PALO ALTO, CALIFORNIA, U.S.A.

MANUAL PART NO. 08484-90014
Microfiche Part No. 08484-90015

Printed: SEPTEMBER 1983

1. GENERAL INFORMATION

2. This Operating and Service Manual contains information about initial inspection, performance tests, adjustments, operation, troubleshooting and repair of the Model 8484A Power Sensor.

3. On the title page of this manual is a "Microfiche" part number. This number can be used to order a 4 x 6-inch microfilm transparency of the manual.

4. Instruments Covered by Manual

5. This instrument has a two-part serial number. The first four digits and the letter comprise the serial number prefix. The last five digits form a sequential suffix which is unique to each instrument. The contents of this manual apply directly to instruments having the serial number prefix listed under SERIAL NUMBERS on the title page.

6. An instrument manufactured after the printing of this manual may have a serial prefix that is not listed on the title page. This unlisted serial prefix indicates that the manual for this instrument is supplied with a yellow Manual Changes supplement containing "change information" that documents the differences.

7. In addition to change information, the supplement may contain information for correcting errors in the manual. To keep this manual as current and accurate as possible, Hewlett-Packard recommends that you periodically request the latest Manual Changes supplement. The supplement is keyed to the manual print date and part number, both of which appear on the title page. Complimentary copies of the supplement are available on request from your nearest Hewlett-Packard office.

8. For information concerning a serial number prefix not listed on the title page or in the Manual Changes supplement, contact your nearest Hewlett-Packard office.

9. Description

10. The HP 8484A Power Sensor is used for measuring the average power supplied by an RF

source to a 50-ohm load. The Power Sensor has a high-sensitivity, capable of measuring power levels as low as 0.1 nanowatt (nW). In use, the Power Sensor is connected to the RF source and to a compatible power meter. (Suitable meters are the HP 435A or 436A Power Meter.) The Power Sensor places a 50-ohm load on the RF source, and the power meter indicates the power dissipated in this load. The power is determined from the RF voltage developed across the Power Sensor load, and is expressed in nW (or μ W) and dBm. The HP 436A Power Meter can also provide readings, in dB, relative to a previous RF input to the Power Sensor.

11. The Power Sensor measures power levels from -70 dBm to -20 dBm (0.1 nW to 10 μ W), at frequencies from 10 MHz to 18 GHz.

12. Calibration data is provided by a graph on the Power Sensor. The graph, individually prepared for each Power Sensor, shows the calibration factor (CAL FACTOR) at 17 frequencies. This calibration factor is used to adjust the power meter to suit the particular Power Sensor and RF frequency. For greater accuracy, a table showing the calibration factor to two significant digits is supplied with each Power Sensor.

13. Specifications for the Power Sensor are provided in Table 1.

14. Accessories Supplied

15. Included with the Power Sensor is the HP 11708A 30 dB Reference Attenuator (Figure 1). This is used to reduce the RF reference voltage applied by the power meter to the Power Sensor when calibrating the system before use. (The calibration procedure adjusts the power meter for the particular Power Sensor and for ambient temperature.) Because of the high sensitivity of the HP 8484A Power Sensor, the 50 MHz 1 mW reference input supplied by the power meter must be reduced to 1 μ W; the Reference Attenuator provides the means to accomplish this. Further, the Reference Attenuator is intended for use at only 50 MHz, the adjustment frequency, and should be used only for calibrating the power meter for a Power Sensor. The Reference Attenuator is a highly accurate device, intended only for this specific function.

Table 1. Specifications

<p>Frequency Range: 10 MHz to 18 GHz.</p> <p>Power Measurement Range: 100 pW to 10 μW (-70 dBm to -20 dBm).</p> <p>Maximum Permissible RF Power, Average or Peak: 200 mW.</p> <p>Maximum dc Voltage to RF Input: 20V.</p> <p>Maximum SWR (Reflection Coefficient) of Power Sensor:</p> <table border="0"> <tr> <td>1.40 (0.167) 10 MHz to 30 MHz</td> <td>1.30 (0.130) 10 GHz to 15 GHz</td> </tr> <tr> <td>1.15 (0.070) 30 MHz to 4 GHz</td> <td>1.35 (0.150) 15 GHz to 18 GHz</td> </tr> <tr> <td>1.20 (0.091) 4 GHz to 10 GHz</td> <td></td> </tr> </table>		1.40 (0.167) 10 MHz to 30 MHz	1.30 (0.130) 10 GHz to 15 GHz	1.15 (0.070) 30 MHz to 4 GHz	1.35 (0.150) 15 GHz to 18 GHz	1.20 (0.091) 4 GHz to 10 GHz	
1.40 (0.167) 10 MHz to 30 MHz	1.30 (0.130) 10 GHz to 15 GHz						
1.15 (0.070) 30 MHz to 4 GHz	1.35 (0.150) 15 GHz to 18 GHz						
1.20 (0.091) 4 GHz to 10 GHz							
<p>Maximum SWR (Reflection Coefficient) of HP 11708A 30 dB Reference Attenuator: 1.05 (0.025) at 50 MHz*.</p> <p>RF Impedance: 50 ohms nominal.</p> <p>RF Connector: Type N Male (meets military specifications).</p> <p>Calibration: Individual calibration graph and table, traceable to NBS, provided with each Power Sensor. The HP 11708A 30 dB Reference Attenuator is manufactured to 30 ± 0.05 dB*, at 50 MHz and 25°C, traceable to NBS, with temperature coefficient typically 0.003 dB per degree C.</p> <p>Dimensions, including RF connector, excluding HP 11708A 30 dB Reference Attenuator: 36 mm wide, 44 mm high, 133 mm long (1-7/16 x 1-3/4 x 5-1/4 in.).</p> <p>Dimensions of HP 11708A 30 dB Reference Attenuator (including RF connector): 20 mm diameter, 60 mm long (0.79 x 2.4 in.).</p> <p>Weight (excluding HP 11708A 30 dB Reference Attenuator): Net, 0.4 kg (13 oz.).</p> <p>Weight of HP 11708A 30 dB Reference Attenuator: Net, 0.085 kg (3 oz.).</p>							
<p>*To verify the specifications of the HP 11708A 30 dB Reference Attenuator to ± 0.073 dB, the test system used must meet the following requirements:</p> <ol style="list-style-type: none"> Attenuation resolution 0.003 dB. Substitution attenuator accuracy ± 0.02 dB. Source and load SWR < 1.02. 							

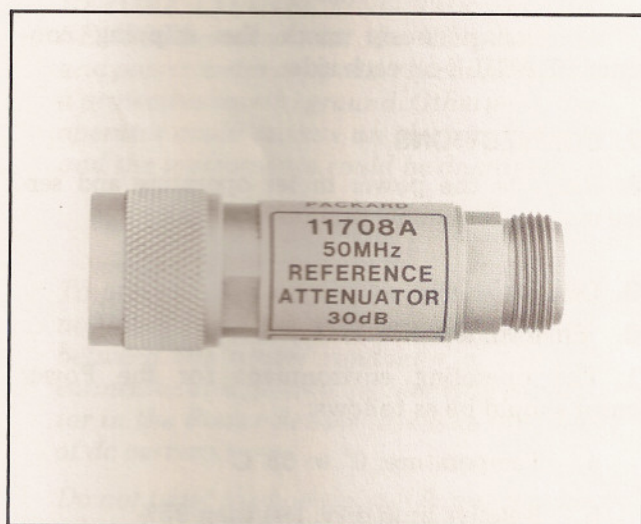

Figure 1. HP 11708A 30 dB Reference Attenuator

16. Options

17. Two options are available for the HP 8484A Power Sensor. The first, Option 002, is a range knob (00435-60030) for the HP 435A Power Meter, permitting more convenient use of power meters which have serial prefix number 1527A and under. HP 435A Power Meters with a higher serial prefix number do not require Option 002. No HP 436A Power Meter requires Option 002.

18. The other option is Option 003. This deletes the HP 11708A 30 dB Reference Attenuator.

19. Recommended Test Equipment

20. Table 2 lists the test equipment recommended to check, adjust, and troubleshoot the Power Sensor. If substitute equipment is used, it must meet or exceed the critical specifications.

Table 2. Recommended Test Equipment

Instrument Type	Critical Specifications	Suggested Model	Use*
Digital Voltmeter	Volts: Range: 100 mVdc to 100 Vdc Input Impedance: 10 megohms Resolution: 4-digit Accuracy: $\pm 0.05\%$ ± 1 digit Resistance: Range: 1 ohm to 100,000 ohms Accuracy: $\pm 5\%$	HP 3435A	T
Oscilloscope	Bandwidth: dc to 50 MHz Sensitivity: Vertical, 0.2 V/div Horizontal, 1 ms/div	HP 180C/1801A/1821A	A, T
10:1 Divider Probe	10 Megohms 10 pF	HP 10004D	A
DC Power Supply	Range: 0–20 Vdc Load Regulation: 0.01% + 4 mV	HP 6204B	T

*A = adjustment, T = Troubleshooting

21. INSTALLATION

22. Initial Inspection

23. Inspect the shipping container. If the container or packing material is damaged it should be kept until the contents of the shipment have been checked mechanically and electrically. If there is mechanical damage or if the instrument does not pass the performance tests, notify the nearest Hewlett-Packard office. Keep the damaged shipping materials (if any) for inspection by the carrier and a Hewlett-Packard representative.

24. Storage and Shipment.

25. **Environment.** The instrument should be stored in a clean, dry environment. The following limitations apply to both storage and shipment:

- a. Temperature -40 to $+75^{\circ}\text{C}$
- b. Relative humidity, less than 95%
- c. Altitude, less than 7 600 metres (25 000 feet).

26. **Packaging.** The following instructions should be used for re-packaging with commercially available materials:

a. Wrap the instrument in heavy paper or plastic. If shipping to a Hewlett-Packard office or service center, attach a tag indicating the type of

service required, return address, model number, and full serial number.

b. Use a strong shipping container. A double-wall carton made of 200 pound test material is adequate.

c. Use enough shock-absorbing material around all sides of the instrument to provide firm cushioning.

d. Seal the shipping container securely.

e. Conspicuously mark the shipping container **FRAGILE** on each side.

27. CONNECTIONS

28. Refer to the power meter operating and service manual for connection instructions.

29. OPERATION

30. Environment

31. The operating environment for the Power Sensor should be as follows:

- a. Temperature, 0° to 55°C
- b. Relative humidity, less than 95%
- c. Altitude, less than 4 572 metres (15 000 feet)

32. The sensitivity of the diode detector in the power sensor is influenced by ambient temperature. This change has been compensated for, but at temperature extremes, the sensor should be recalibrated to obtain the most accurate results. Typical temperature sensitivity variations are shown in Figure 2.

33. To recalibrate the sensor, allow it to stabilize in the test thermal environment for approximately one hour (for a step change in temperature). Then recalibrate using the 11708A, the power meter's reference oscillator, and the CAL ADJ control. The sensor is properly calibrated when it will remain zeroed for 20 seconds.

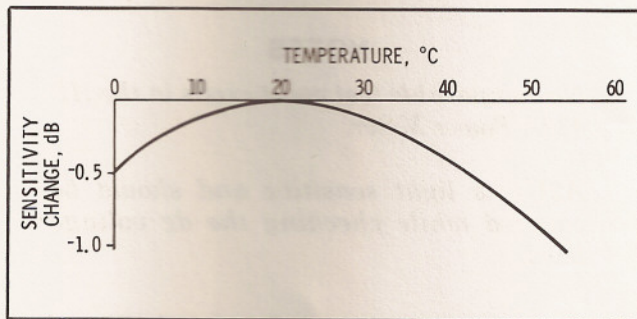

Figure 2. Typical Influence of Temperature on Sensitivity

34. Operating Precautions

35. Before the Power Sensor is connected, the following precautions must be observed.

WARNING

BEFORE CONNECTING THE POWER SENSOR, ensure that the RF generator and power meter are properly connected to a protective (earth) ground. Otherwise, the operator could receive an electrical shock and the instruments could be damaged.

CAUTION

To prevent damage to the Power Sensor, no more than 20 Vdc may be applied between the center conductor of the RF connector and ground. (A blocking capacitor in the Power Sensor prevents the flow of dc current.)

Do not twist the body of the Power Sensor when connecting and disconnecting it. Twisting can cause major damage to the Power Sensor's circuits.

36. When the power meter is being calibrated for use with the HP 8484A Power Sensor, the HP 11708A 30 dB Reference Attenuator must be used. It is installed on the Power Sensor RF connector, and the other end is installed on the POWER REF OUTPUT jack on the HP 435A or 436A Power Meter. Calibration is then performed as follows:

a. For the HP 435A Power Meter, set the RANGE switch to 1 μ W, and adjust the CAL ADJ control to bring the needle on the meter to the CAL position.

b. For the HP 436A Power Meter, adjust the CAL ADJ control to obtain a reading of 1 μ W on the digital display.

37. It should be noted that the HP 11708A Reference Attenuator is a precise device, intended for use only at 50 MHz, and only for calibrating the HP 435A and 436A Power Meters. The accuracy of the attenuator cannot be guaranteed in other uses.

38. Operating Procedures

39. Instructions for use of the Power Sensor are provided in the power meter manual. Note, however, the different calibration procedure described in paragraph 36 above. During operation, the precautions in paragraph 35 must be observed.

40. Table 3 shows the uncertainties in the calibration factor, traceable to the National Bureau of Standards (NBS). This information, when added to other sources of uncertainty, allows measurements to be defined in terms of primary standards. Do not make power readings below 0.1 nW; the noise level makes such readings unreliable.

Table 3. Uncertainty of 8484A Calibration Factor

Frequency (GHz)	Worst Case Uncertainty (%)	RSS Uncertainty (%)*
2.0	4.9	2.2
4.0	4.6	2.0
6.0	4.9	2.1
8.0	5.3	2.3
10.0	5.5	2.5
12.4	6.4	2.8
14.0	6.1	3.1
16.0	7.8	3.4
18.0	8.1	3.6

*Square root of the sum of the squared individual uncertainties.

41. SWR (REFLECTION COEFFICIENT) PERFORMANCE TEST

42. The maximum SWR and reflection coefficient for the Power Sensor are listed in Table 4. For making these measurements, use equipment which has measurement uncertainties not exceeding those shown in the table. During measurement, the RF power dissipated by the Power Sensor should not exceed -20 dBm (10 microwatts) at all frequencies.

43. FET BALANCE ADJUSTMENT†

44. Capacitors A2C2 and A2C12 are marked with asterisks on the schematic diagram and in the parts list. The asterisk indicates that these are factory-selected components chosen to suit integrated circuit A2U1 in the Power Sensor. The nominal capacitance value is shown, but the actual value and part number may be different. Only one of the capacitors will typically be used or they both might be omitted.

NOTE

The FET balance has been factory adjusted with a nominal power meter and may exceed the 0.8 Vp-p switching transient and the ±0.2 mV Auto Zero signal when measured with another power meter. This adjustment should only be required if the A2U1 Assembly is changed or the associated wires are moved.

45. Capacitors A2C2 and C12 control the dc voltage level at U1-pin 2. They also affect the balance of the sampling gate drive voltage, but only slightly.

46. The relative position of the wires which connect to pins G and H of connector J1 in the Power Sensor have the largest effect on the switching transients (voltage spikes). One wire is black on white and the other is brown on white. Care must be used not to displace these wires.

NOTE

The position of the black and yellow on white (the output to the power meter) may also affect the voltage spike amplitude.

47. To find the correct values for A2C2 and A2C12 and to find the correct position for the wires, perform the procedure found in the following paragraphs after connecting a DVM and oscilloscope to:

a. test point A4TP4 in the HP 435-series power meters, or

b. test point A1TPAC(3) in the HP 436A Power Meter.

NOTES

No comparable test point exists in the HP 438A Power Meter.

A2U1 is light sensitive and should be covered while checking the dc voltage level.

48. Press the auto zero switch; select A2C2 and/or C12 for a voltage between +6 and -2 mVdc. A higher value of C12 will cause the dc voltage to go more positive; a higher value of C2 will cause the voltage to go more negative.

49. Various values for A2C2 and C12 should be tried. The value should range from no capacitance to a maximum value of 10 pF. Solder the capacitor in place only after a suitable value has been found. (Refer to paragraph 73 for special soldering instructions.)

50. Monitor the voltage transient spikes with an oscilloscope. Position the wires mentioned in paragraph 46 to reduce the voltage spikes to less than 0.8 Vp-p.

Table 4. SWR and Reflection Coefficient

Frequency	Measuring System Reflection Coefficient Uncertainty	Actual Measurement	Maximum SWR (Reflection Coefficient)
10 MHz to 30 MHz	±0.015	_____	1.40 (0.167)
30 MHz to 4 GHz	±0.015	_____	1.15 (0.070)
4 GHz to 10 GHz	±0.025	_____	1.20 (0.091)
10 GHz to 15 GHz	±0.035	_____	1.30 (0.130)
15 GHz to 18 GHz	±0.035	_____	1.35 (0.150)

†Refer to the Appendix for backdating information.

51. REPLACEABLE PARTS

52. Table 5 is a list of replaceable parts. Figure 3 illustrates the major parts. To order a part, quote the Hewlett-Packard part number, specify the quantity required, and address the order to the nearest Hewlett-Packard office. To order a part not listed in Table 5, give the instrument model number, instrument serial number, the description and function of the part, and the quantity of parts required.

53. SERVICE

54. Test equipment which meets or exceeds the critical specifications in Table 2 may be used in place of the recommended instruments for troubleshooting the Power Sensor.

55. Figure 4 shows the locations of the assemblies and components. Figure 5 is the schematic diagram.

Table 6-3. Replaceable Parts

Reference Designation	HP Part Number	C D	Qty	Description	Mfr Code	Mfr Part Number
A1	00484-60005	7	1	BULKHEAD ASSEMBLY, RESTORED REPLACEMENT	28480	00484-60005
A2	00484-60001	3	1	INPUT AMPLIFIER ASSEMBLY	28480	00484-60001
A2C1	0180-0679	1	1	CAPACITOR-FXD 8.2UF+-5% 50VDC TA	56289	102DR825X9015L
A2C2*	0160-2247	1	2	CAPACITOR-FXD 3.9PF +-20% 50VDC CER	28480	0160-2247
A2C3	0160-4306	7	4	CAPACITOR-FXD 100PF +-5% 50VDC CER	51959	0005C101K3P
A2C4	0160-4306	7	2	CAPACITOR-FXD 100PF +-5% 50VDC CER	51959	0005C101K3P
A2C5†	0180-0642	8	1	CAPACITOR-FXD 15UF+-20% 25VDC TA	25088	D156S1B20M
A2C6	0160-3094	8	1	CAPACITOR-FXD .1UF +-5% 50VDC CER	28480	0160-3094
A2C7	0160-3879	7	1	CAPACITOR-FXD .01UF +-20% 50VDC CER	28480	0160-3879
A2C8	0160-4306	7	1	CAPACITOR-FXD 100PF +-5% 50VDC CER	51959	0005C101K3P
A2C9	0160-4306	7	1	CAPACITOR-FXD 100PF +-5% 50VDC CER	51959	0005C101K3P
A2C10	0180-0678	0	1	CAPACITOR-FXD 220UF+-20% 25VDC TA	56289	1B3DR227X0003F
A2C11	0180-0594	9	1	CAPACITOR-FXD 3.3UF+-20% 50VDC TA	28480	0180-0594
A2C12*†	0160-2247	1	1	CAPACITOR-FXD 3.9PF +-20% 50VDC CER	28480	0160-2247
A2CR1	1901-0518	8	1	DIODE-5M SIG SCHOTTKY	28480	1901-0518
A2Q1	1854-0610	0	1	TRANSISTOR NPN SI TO-18 67-MHz	28480	1854-0610
A2R1	0698-7239	0	1	RESISTOR 1.33K 1% .05W F TO-18-100	24546	C3-1/8-T0-1331-F
A2R2	0698-7273	2	1	RESISTOR 34.8K 1% .05W F TO-18-100	24546	C3-1/8-T0-3482-F
A2R3	0698-8619	2	1	RESISTOR 21.5 1% .05W F TO-18-100	28480	0698-8619
A2R4	0698-7224	3	1	RESISTOR 316 1% .05W F TO-18-100	24546	C3-1/8-T0-316R-F
A2R5	0698-8616	9	1	RESISTOR 8.46K 1% .05W F TO-18-100	28480	0698-8616
A2R6	0698-8617	0	1	RESISTOR 5.31K 1% .05W F TO-18-100	28480	0698-8617
A2R7	0698-8618	1	1	RESISTOR 4.12K 1% .05W F TO-18-100	28480	0698-8618
A2U1	1813-0060	8	1	IC TO-8 PKG	28480	1813-0060
A2 MISCELLANEOUS PARTS						
	5040-6938	6	1	SPACE-CHOPPER	28480	5040-6938
	1251-3172	7	1	CONNECTOR	28480	1251-3172
CHASSIS MISCELLANEOUS PARTS						
J1†	5180-2702	0	1	CONNECTOR-12-CONT,FER,CONE,INSIDE	28480	5180-2702
HP1	00484-20015	5	1	HOUSING	28480	00484-20015
MP2	00481-20011	8	2	CHASSIS	28480	00481-20011
MP3	00481-20011	8	1	CHASSIS	28480	00481-20011
MP4	00484-20016	6	1	FLANGE, FRONT, OUTER	28480	00484-20016
MP5	00484-20018	8	1	FLANGE, REAR, OUTER	28480	00484-20018
MP6	00484-20019	9	1	RING LOCK	28480	00484-20019
MP7	00484-20020	2	1	FLANGE, REAR, INNER	28480	00484-20020
MP8	1251-3363	8	1	NUT,CONN,RND SPANNER NUT,ALUMI TYPE CONN	28480	1251-3363
MP9	3030-0436	4	6	SCREW-SKT HD CAP 0-80 .5-24-1/2 SST 300	00000	ORDER BY DESCRIPTION
MP10†	1460-1978	0	1	SPRING-CPRSN .088-IN-OD .180-IN-LG	28480	1460-1978
MP11	5040-6939	7	1	CLAMP	28480	5040-6939
MP12	5040-6940	0	1	BLOCK	28480	5040-6940
MP13	3030-0491	1	2	SCREW-SET 2-56 .312-IN-LG COP-PT ALY STL	00000	ORDER BY DESCRIPTION
MP14	3030-0491	1	1	SCREW-SET 2-56 .312-IN-LG COP-PT ALY STL	00000	ORDER BY DESCRIPTION
MP15	0520-0166	3	1	SCREW-MACH 2-56 .375-IN-LG SS 302	00000	ORDER BY DESCRIPTION
MP16	0520-0164	1	7	SCREW-MACH 2-56 .25-IN-LG SS 302	00000	ORDER BY DESCRIPTION
MP17	0520-0164	1	1	SCREW-MACH 2-56 .25-IN-LG SS 302	00000	ORDER BY DESCRIPTION
MP18	0520-0164	1	1	SCREW-MACH 2-56 .25-IN-LG SS 302	00000	ORDER BY DESCRIPTION
MP19	0520-0164	1	1	SCREW-MACH 2-56 .25-IN-LG SS 302	00000	ORDER BY DESCRIPTION
MP20	0520-0164	1	1	SCREW-MACH 2-56 .25-IN-LG SS 302	00000	ORDER BY DESCRIPTION
MP21	0520-0164	1	1	SCREW-MACH 2-56 .25-IN-LG SS 302	00000	ORDER BY DESCRIPTION
MP22	0520-0164	1	1	SCREW-MACH 2-56 .25-IN-LG SS 302	00000	ORDER BY DESCRIPTION
MP23	3030-0436	4	4	SCREW-SKT HD CAP 0-80 .5-24-1/2 SST 300	00000	ORDER BY DESCRIPTION
MP24	3030-0436	4	4	SCREW-SKT HD CAP 0-80 .5-24-1/2 SST 300	00000	ORDER BY DESCRIPTION
MP25	3030-0436	4	4	SCREW-SKT HD CAP 0-80 .5-24-1/2 SST 300	00000	ORDER BY DESCRIPTION
MP26	3030-0436	4	4	SCREW-SKT HD CAP 0-80 .5-24-1/2 SST 300	00000	ORDER BY DESCRIPTION
MP27	3030-0436	4	4	SCREW-SKT HD CAP 0-80 .5-24-1/2 SST 300	00000	ORDER BY DESCRIPTION
MP28	2190-0049	2	4	WASHER-LK HLCL NO. 0 .045-IN-OD	28480	2190-0049
MP29	2190-0049	2	2	WASHER-LK HLCL NO. 0 .045-IN-OD	28480	2190-0049
MP30	2190-0049	2	2	WASHER-LK HLCL NO. 0 .045-IN-OD	28480	2190-0049
MP31	2190-0049	2	2	WASHER-LK HLCL NO. 0 .045-IN-OD	28480	2190-0049
MP32	3030-0422	8	8	SCREW-SKT HD CAP 0-80 .5-24-1/2 SST 302	00000	ORDER BY DESCRIPTION
MP33	3030-0422	8	8	SCREW-SKT HD CAP 0-80 .5-24-1/2 SST 302	00000	ORDER BY DESCRIPTION
MP34	3030-0422	8	8	SCREW-SKT HD CAP 0-80 .5-24-1/2 SST 302	00000	ORDER BY DESCRIPTION
MP35	3030-0422	8	8	SCREW-SKT HD CAP 0-80 .5-24-1/2 SST 302	00000	ORDER BY DESCRIPTION
MP36	3030-0422	8	8	SCREW-SKT HD CAP 0-80 .5-24-1/2 SST 302	00000	ORDER BY DESCRIPTION
MP37	3030-0422	8	8	SCREW-SKT HD CAP 0-80 .5-24-1/2 SST 302	00000	ORDER BY DESCRIPTION
MP38	3030-0422	8	8	SCREW-SKT HD CAP 0-80 .5-24-1/2 SST 302	00000	ORDER BY DESCRIPTION
MP39	3030-0422	8	8	SCREW-SKT HD CAP 0-80 .5-24-1/2 SST 302	00000	ORDER BY DESCRIPTION
MP40	4208-0096	0	1	FOAM-GRAY PLASTIC	28480	4208-0096
MP41	00435-60030	3	1	KNOB ASSEMBLY-RANGE (OPT 840 ONLY)	28480	00435-60030
R1	0698-7260	7	1	RESISTOR 10K 1% .05W F TO-18-100	24546	C3-1/8-T0-1002-F

See introduction to this section for ordering information

*Indicates factory selected value

†Refer to the Appendix for backdating information

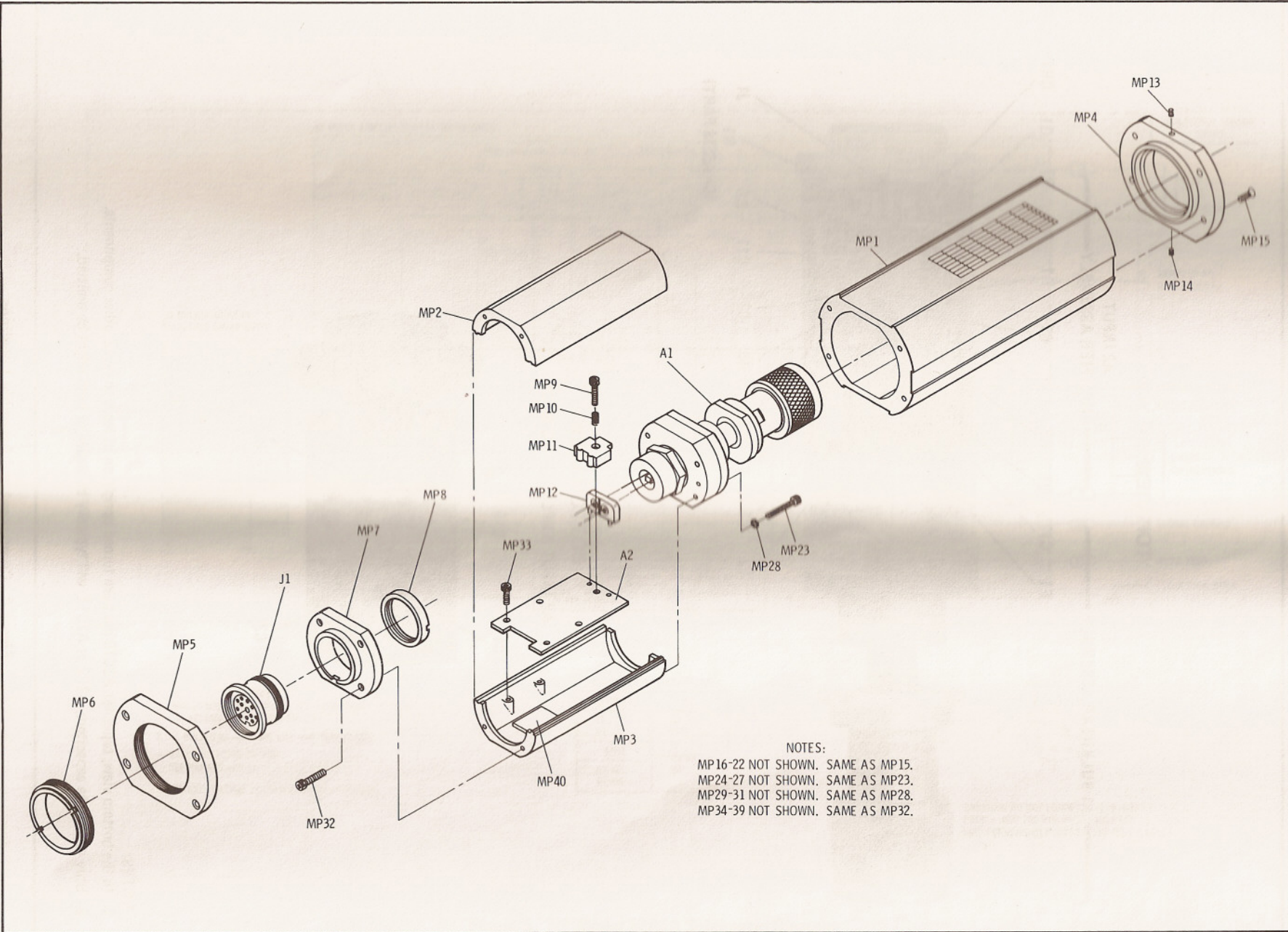

NOTES:
MP16-22 NOT SHOWN. SAME AS MP15.
MP24-27 NOT SHOWN. SAME AS MP23.
MP29-31 NOT SHOWN. SAME AS MP28.
MP34-39 NOT SHOWN. SAME AS MP32.

Figure 3. Illustrated Parts Breakdown

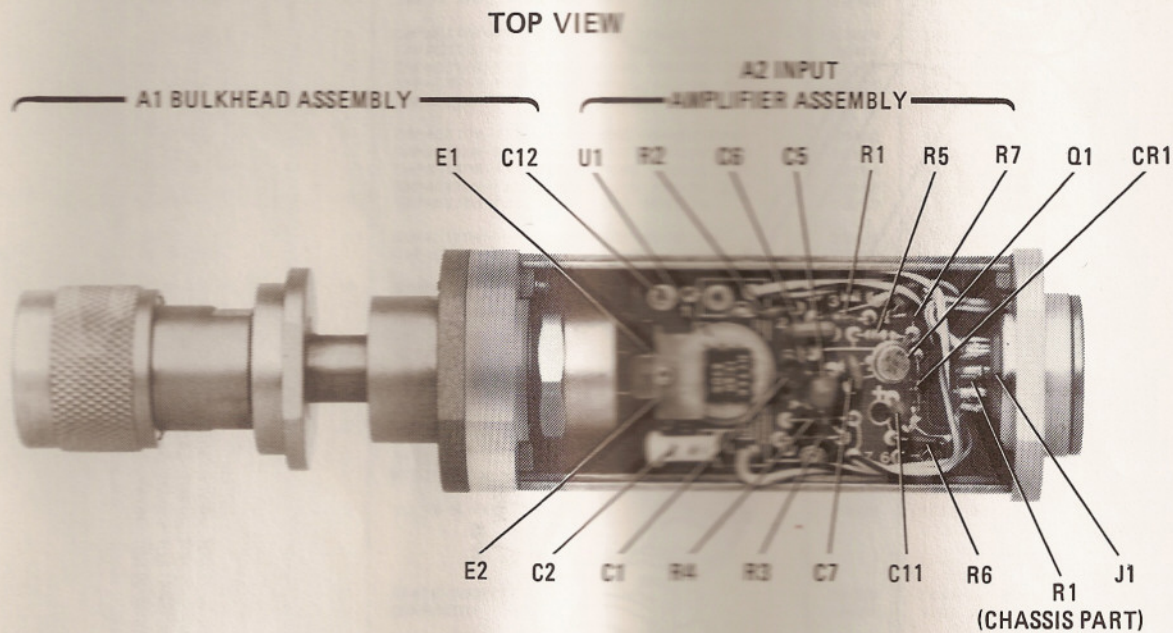

BOTTOM VIEW
A2 INPUT AMPLIFIER ASSEMBLY

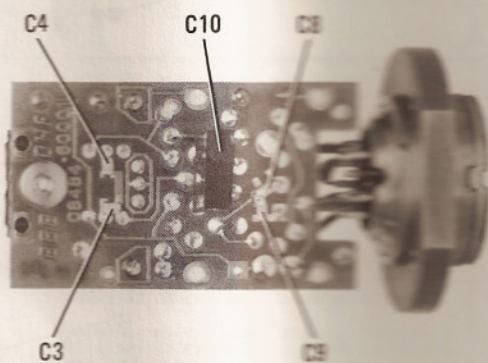

NOTES:

1. In the bottom view, capacitor A2C10 has been turned upright on its leads to reveal other components.
2. Only one of the capacitors, A2C2 or A2C12, will typically be loaded or both might be omitted.

Figure 4. Component and Assembly Locations

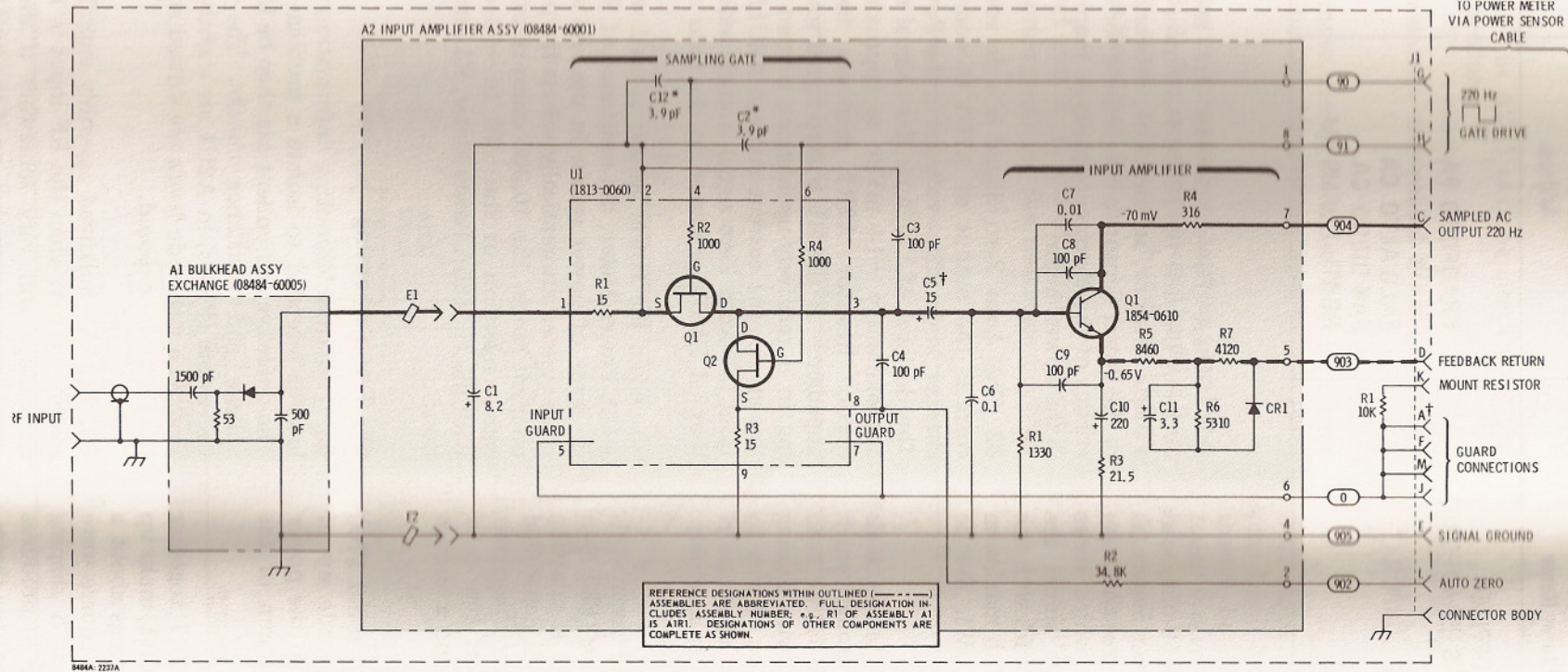

- NOTES:
- UNLESS OTHERWISE INDICATED: RESISTANCE IN OHMS; CAPACITANCE IN MICROFARADS.
 - A1 BULKHEAD ASSEMBLY IS NOT REPAIRABLE.
- * VALUE SELECTED IN TEST. SEE PARAGRAPH 43.
- † SEE BACKDATING INFORMATION IN APPENDIX

REFERENCE DESIGNATIONS

NO PREFIX	A2
J1	C1-C12
R1	CR1
A2U1	Q1
Q1-Q2	R1-R7
R1-R4	U1

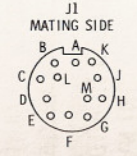
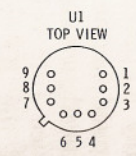

CAUTION: DO NOT FORCE LARGE-DIAMETER TEST PRODS INTO THE PIN RECEPTACLES OF J1. THIS MAY PERMANENTLY DEFORM THE RECEPTACLES.

Figure 5. HP Model 8484A Schematic Diagram

Table 6. Manufacturer's Code List

Mfr. No.	Manufacturer Name	Address	Zip Code
00000	ANY SATISFACTORY SUPPLIER		
2454E	CORNING GLASS WORKS (BRADFORD)	BRADFORD PA	16701
2508E	SIEMENS CORP	ISELIN NJ	08830
2848D	HENLETT-PACKARD CO CORPORATE HQ	PALO ALTO CA	94304
5195B	VIOLAN INC	SAN DIEGO CA	92138
5628B	SPRAGUE ELECTRIC CO	NORTH ADAMS MA	01247

56. Principles of Operation

57. Bulkhead assembly A1 presents a 50-ohm load to the RF signal applied to the Power Sensor. A diode in the bulkhead assembly rectifies the applied RF to produce a dc voltage which varies with the square of the RF voltage across the 50-ohm load. Thus, the dc voltage varies with the RF power dissipated in the load. With maximum measurable RF input power ($10 \mu\text{W}$), the dc voltage is approximately -5 mV .

58. Components A1R1 and A1R2 are ferrite beads situated in the black plastic block through which the wires from A1 pass to A2. Each ferrite bead increases the self-inductance of the wire passing through the bead, causing this portion of wire to act as an RF choke. The result is to minimize rf feedthrough to the A2 input amplifier assembly.

59. The dc output from the bulkhead assembly is applied to the two field-effect transistors (FET's) in A2U1. These transistors function as a sampling gate (or diodes). The sampling rate is controlled by a 220-Hz square wave supplied by the power meter. The sampling gate output (at pin 3 of A2U1) is a 220-Hz square wave having a voltage proportional to the RF power input.

60. The output of A2U1 is amplified about 1700 times by an operational amplifier made up of A2U2 and the first amplifier stage in the power meter. Figure 6 is a simplified diagram of the complete operational amplifier.

61. Resistor A2R5, A2R6, and A2R7 together with capacitor A2C11 and diode A2CR1, make up a shaping network. This network brings about a linear change in the amplitude of the square wave output as RF input power changes. A shaping network in the power meter (Figure 6) produces the same effect when a power sensor of the thermocouple type is used. (HP Model 8481A, 8482A,

and 8483A Power Sensors are thermocouple devices.) Because the HP 8484A Power Sensor uses a diode detector, an additional network is required in the Power Sensor to compensate for the characteristics of the thermocouple-type shaping network in the power meter.

62. The Auto Zero Signal is a dc voltage which corrects the output of A2U1 to compensate for changes in dc offset voltages in the Power Sensor. The dc level of the Auto Zero signal ranges from approximately -14 mVdc to approximately $+14 \text{ mVdc}$. Resistor A2R2 increases the effective impedance of the Auto Zero signal source, resulting in a relatively-unchanging current source. By this means, the current through A2U1R3 resulting from the Auto Zero signal is made independent of thermal EMF's produced in the auto zero circuit.

63. When the Power Sensor is used with the HP 435A Power Meter, the resistance of R1 indicates the type of power sensor in use. As a result, the power meter automatically selects the proper measurement range. The 10,000 ohms resistance of R1 causes selection of the -70 to -20 dBm range. With the HP 435A Power Meter, R1 serves no function.

64. Troubleshooting

65. The troubleshooting information which follows is intended to isolate a problem to a stage. The defective component can then be identified by voltage and resistance checks. The field-effect transistor (FET's) in A2U1 are slightly light sensitive. As a result, dc levels are shifted slightly when the FET's are exposed.

66. The A1 bulkhead assembly supplies approximately -5 mV when the RF input is $10 \mu\text{W}$. This dc voltage will vary somewhat if the A2 input amplifier is inoperative, or if the bulkhead assembly is disconnected from the input amplifier. The

A1 bulkhead assembly is not a repairable item, and the entire unit should be replaced if defective.

67. The FET's in A2U1 may be checked by the following procedure:

- a. Disconnect the cables from the Power Sensor.
- b. Remove the upper chassis from the Power Sensor. (Refer to disassembly procedures, paragraph 76.)
- c. Measure the resistance between pins 1 and 2 of the A2U1. The resistance should be 15 ± 0.75 ohms. The same resistance should be found between pins 8 and 9 of A2U1.
- d. Short pins E, G and H of J1. While the pins are shorted, measure the resistance between

pins 2 and 3, and between pins 3 and 8, of A2U1. The resistance should be less than 40 ohms.

- e. Set a power supply to 10 Vdc.
- f. Connect the positive side of the power source to the Power Sensor signal ground. Connect the negative power supply lead to pins 4 and 6 of A2U1.
- g. Measure the resistance between pins 2 and 3 of A2U1. Also measure the resistance between pins 3 and 8 of A2U1. In both cases, the resistance should be several hundred times the resistance found in step d.

68. The 220 Hz drive from the power meter should have the following levels:

- a. -0.05 ± 0.05 Vdc (top of square wave).
- b. > -9 Vdc (bottom of square wave).

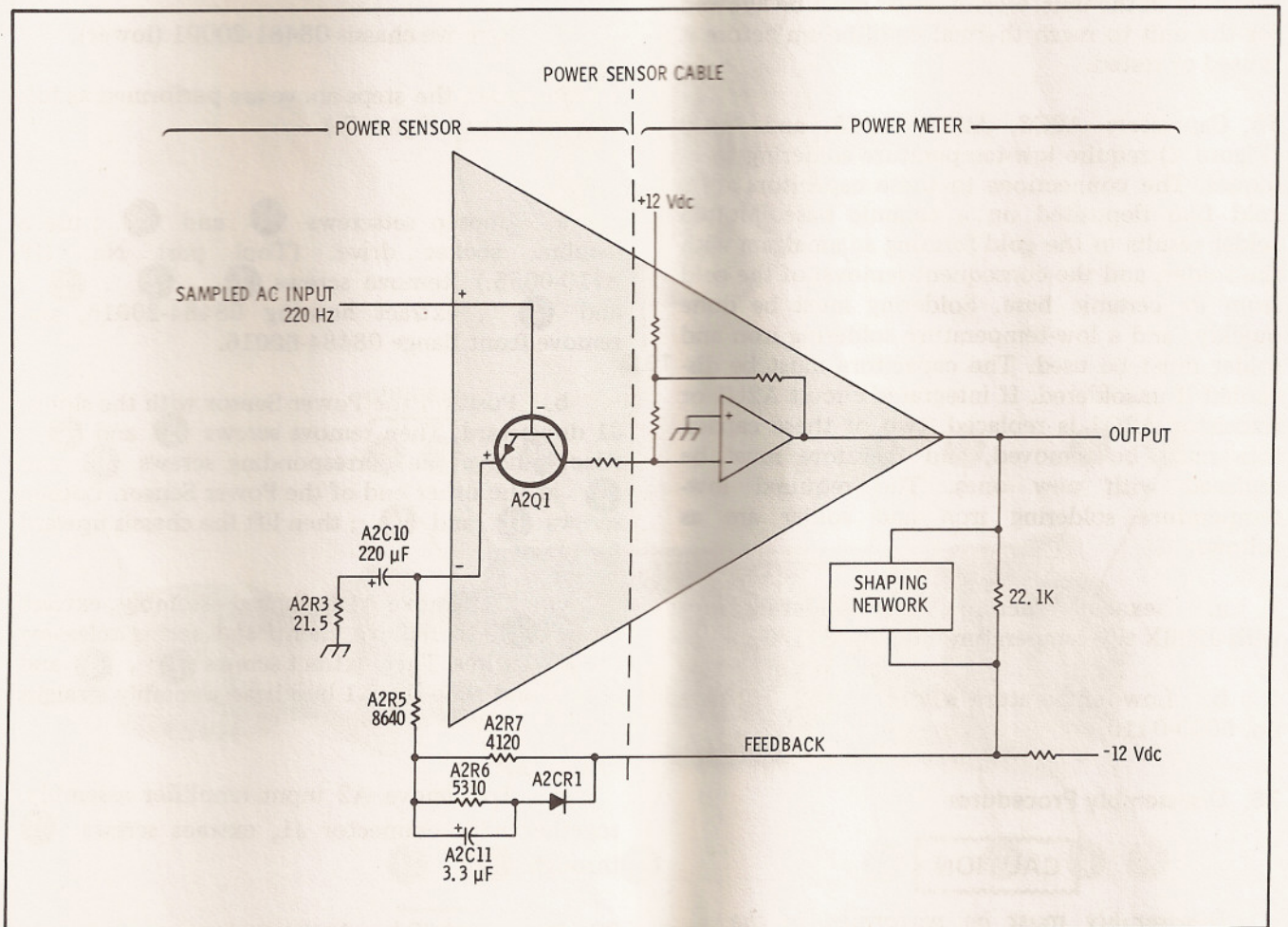

Figure 6. Operational Amplifier

69. In most cases it may be assumed that the operational amplifier (made up of A2Q1 and the first amplifier is the power meter) is operating correctly if the dc voltage on the metal cover of A2Q1 (collector) is -70 ± 30 mVdc. If the 8484A seems noisy, the most likely source is the transistor A2Q1.

70. REPAIR

71. Cleanliness

72. Do not handle the A2 input amplifier circuit board more than necessary. Dirt or moisture from the hands may make the circuits inoperative. Do not use solder-flux remover on the circuit board. It is particularly important to keep the area around A2U1 clean.

73. Soldering Techniques

74. The HP 8484A Power Sensor is a high-sensitivity device, and is affected by very small differences in temperature between its components. Therefore, after the performance of any soldering in the unit, *several hours* must be allowed for the unit to reach thermal equilibrium before it is used or tested.

75. Capacitors A2C3, A2C4, A2C8, and A2C9 (Figure 4) require low-temperature soldering techniques. The connections to these capacitors are a gold film deposited on a ceramic base. Molten solder results in the gold forming an amalgam with the solder, and the consequent removal of the gold from its ceramic base. Soldering must be done quickly, and a low-temperature soldering iron and solder must be used. The capacitors must be discarded if unsoldered. If integrated circuit A2U1 or transistor A2Q1 is replaced, two of these capacitors must be removed, and therefore must be replaced with new ones. The required low-temperature soldering iron and solder are as follows:

a. Hexacon Thermo-O-Trac soldering iron with J206X tip, temperature 600° F (311° C).

b. Low-temperature solder SN 62, HP part no. 5090-0410.

76. Disassembly Procedures

CAUTION

Disassembly must be performed in the sequence described below, otherwise damage may be caused to the two gold wires between the A1 bulkhead assembly

and the A2 input amplifier assembly. If these wires are damaged, the A1 bulkhead assembly must be returned to the factory for repair.

Each Power Sensor has an individually prepared graph on housing 08484-20015. If more than one Power Sensor is disassembled, be sure to use the proper housing for each when they are reassembled.

77. Disassembly of the HP 8484A Power Sensor requires the following steps, described in detail in the next paragraph.

a. Remove housing 08484-20015 and front flange 08484-20016.

b. Remove chassis 08481-20001 (upper).

c. Remove A1 bulkhead assembly.

d. Remove chassis 08481-20001 (lower).

78. In detail, the steps above are performed as follows. (Refer to Figure 7.)

a. Loosen setscrews 19 and 20; use a 4-spine socket drive. (Tool part No. HP 8710-0055.) Remove screws 1, 2, 3, and 4, extract housing 08484-20015, and remove front flange 08484-60016.

b. Position the Power Sensor with the slot in J1 downward. Then remove screws 5 and 6. Also, remove the corresponding screws 17 and 18 at the other end of the Power Sensor. Loosen screws 13 and 14; then lift the chassis upward for removal.

c. To remove A1 bulkhead assembly, extract screw 7 to remove clamp and spring releasing the guid wires. Then extract screws 8, 9 and 10, and slide the A1 bulkhead assembly straight out.

d. To remove A2 input amplifier assembly, together with connector J1, extract screws 11 through 15.

79. Reassembly Procedures

a. If capacitor A2C10 (beneath the A2 circuit board) has been turned upright on its leads,

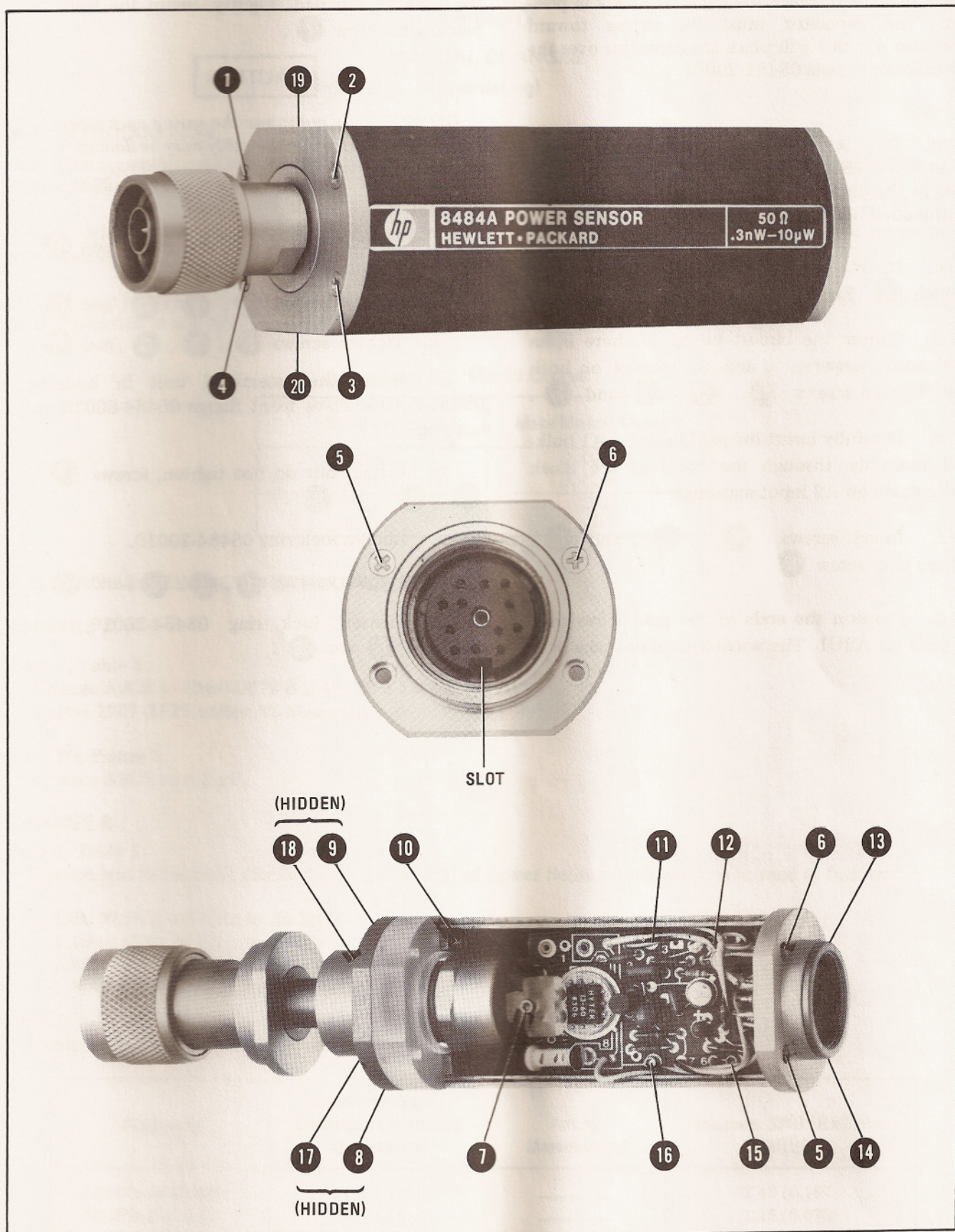

Figure 7. Power Sensor Disassembly and Assembly

bend the leads to place the capacitor back in position. The capacitor must be swung toward connector J1; this will place the capacitor over the pad in lower chassis 08481-2001L.

b. Place A1 Input Amplifier Assembly, with J1, in lower chassis 08481-2001L. The four screw holes in the circuit board must be positioned over the threaded holes in the chassis.

c. Insert, but do not tighten, screws 11 through 15. Refer to Figure 7.

d. Center the circuit board so there is an equal space between it and the chassis on both sides. Tighten screws 11, 12, 15, and 16.

e. Carefully insert the gold leads on A1 bulk-head assembly through the holes in the black plastic guide on A1 input amplifier.

f. Insert screws 8, 9, and 10. Tighten only screw 10.

g. Position the ends of the gold wires over the pads on A2U1. The wires should not pass over

the hole in the pad. Lightly clamp the leads in place with screw 7.

CAUTION

DO NOT fully compress the spring with screw 7, or the A2U1 Assembly may be damaged.

h. Place upper chassis 08481-2001 in position.

i. Insert, but do not tighten, screws 17, 18, 5, and 6.

j. Tighten screws 8, 9, 17, and 18.

k. Tighten screws 5, 6, 13, and 14.

l. Insert the assembled unit in housing 08484-20015. Place front flange 08484-60016 on housing.

m. Install, but do not tighten, screws 1, 2, 3, and 4.

n. Loosen lock ring 08484-20019.

o. Tighten screws 1, 2, 3, and 4.

p. Tighten lock ring 08484-20019, and setscrews 19 and 20.

APPENDIX
MANUAL CHANGES
(Backdating)

A-1. INTRODUCTION

A-2. This appendix contains information for adapting this manual to instruments for which the content does not directly apply.

A-3. To adapt this manual to your instrument, refer to Table A-1 and make all the changes listed opposite your instrument serial number. Perform these changes in the sequence listed.

A-4. If your instrument serial number is not listed on the title page of this manual (or in Table A-1), it may be documented in a MANUAL CHANGES supplement.

Table A-1. Manual Changes

Serial Prefix	Make Manual Changes
1528A	D, C, B, A
1635A	D, C, B
1916A 2046A	D, C D

A-5. MANUAL CHANGE INSTRUCTIONS

CHANGE A

Page 7, Table 5:
Change A2C5 to 0180-0679 8.2 UF 10% 15 WVDC TANT
Delete 1251-3172 under A2 Miscellaneous

Page 10, Figure 5:
Change A2C5 to 8.2 μ F.

CHANGE B

Page 3, Table 1:
Change Maximum SWR (Reflection Coefficient) of Power Sensor specifications to read as follows:

- 1.40 (0.167) 10 MHz to 30 MHz
- 1.15 (0.070) 30 MHz to 4 GHz
- 1.20 (0.091) 4 GHz to 10 GHz
- 1.30 (0.130) 10 GHz to 18 GHz

Page 6, Table 4:
Replace Table 4, SWR and Reflection Coefficient, with the following:

Frequency	Measuring System Reflection Coefficient Uncertainty	Actual Measurement	Maximum SWR (Reflection Coefficient)
10 MHz to 30 MHz	± 0.015	_____	1.40 (0.167)
30 MHz to 4 GHz	± 0.015	_____	1.15 (0.070)
4 GHz to 10 GHz	± 0.025	_____	1.20 (0.091)
10 GHz to 18 GHz	± 0.035	_____	1.30 (0.130)

Page 10

CHANGED

Page 6, paragraph 4.4.2

Delete all references to capacitor ABC12.

Page 7, Table 1

Delete ABC12.

Page 8, Figure 1

In the top row of the table, delete the references to ABC12.

Page 10, Figure 2

Delete ABC12.

CHANGED

Page 7, Table 1

It was originally 1234-5678. However, the part listed in the table is the recommended replacement.

Therefore, no manual change is suggested.

XYZ9 was originally 1000-1111. However, the part listed in the table is the recommended replacement.

Therefore, no manual change is suggested.

Page 10, Figure 2

Delete XYZ9.

POWER SENSOR

MANUAL IDENTIFICATION

Model Number: HP 8484A
Date Printed: September 1983
Part Number: 08484-90014

This supplement contains important information for correcting manual errors and for adapting the manual to instruments containing improvements made after the printing of the manual.

To use this supplement:

Make all ERRATA corrections

Make all appropriate serial number related changes indicated in the tables below.

Serial Prefix or Number	Make Manual Changes	Serial Prefix or Number	Make Manual Changes
2349A	1, 2		
2349A13826	1, 2		
2634A	1, 2		
▶2645A	1—3		

▶ NEW ITEM

ERRATA

Page 5, Paragraph 36:

Add the following before step a:

Enter the REFERENCE CAL FACTOR according to the instructions on the power sensor label.

Add the following after step b.

- c. For the HP 438A Power Meter the following procedure will automatically calibrate the Power Meter and Power Sensor to 1 mW (1 μ W will be displayed on the front panel because of the use of the HP 11708 30 dB attenuator):
- Press CAL ADJ
 - Enter the reference CAL FACTOR value
 - Press ENTER

Page 8, Table 6-3:

A2R3. Change the part number for A2R3 to the following: 0698-7196 CD8

J1. The recommended replacement for J1, if it fails, is found in **CHANGE 1**.

MP28 through MP31. Change the part numbers and descriptions for MP28 through MP31 to the following:

2190-0572 CD6 WASHER-LK HLCL NO. 0 .062-IN-ID .1-IN-OD

MP32 and MP34—MP36. The recommended replacement for MP32 and MP34—MP36, if they need to be replaced, is found in **CHANGE 2**.

MP33. Add the following to the description for MP33:

(Used four places to mount the printed circuit board.)

MP37 through MP39. Delete MP37 through MP39.

NOTE

Manual change supplements are revised as often as necessary to keep manuals as current and accurate as possible. Hewlett-Packard recommends that you periodically request the latest edition of this supplement. Free copies are available from all HP offices. When requesting copies quote the manual identification information from your supplement, or the model number and print date from the title page of the manual.

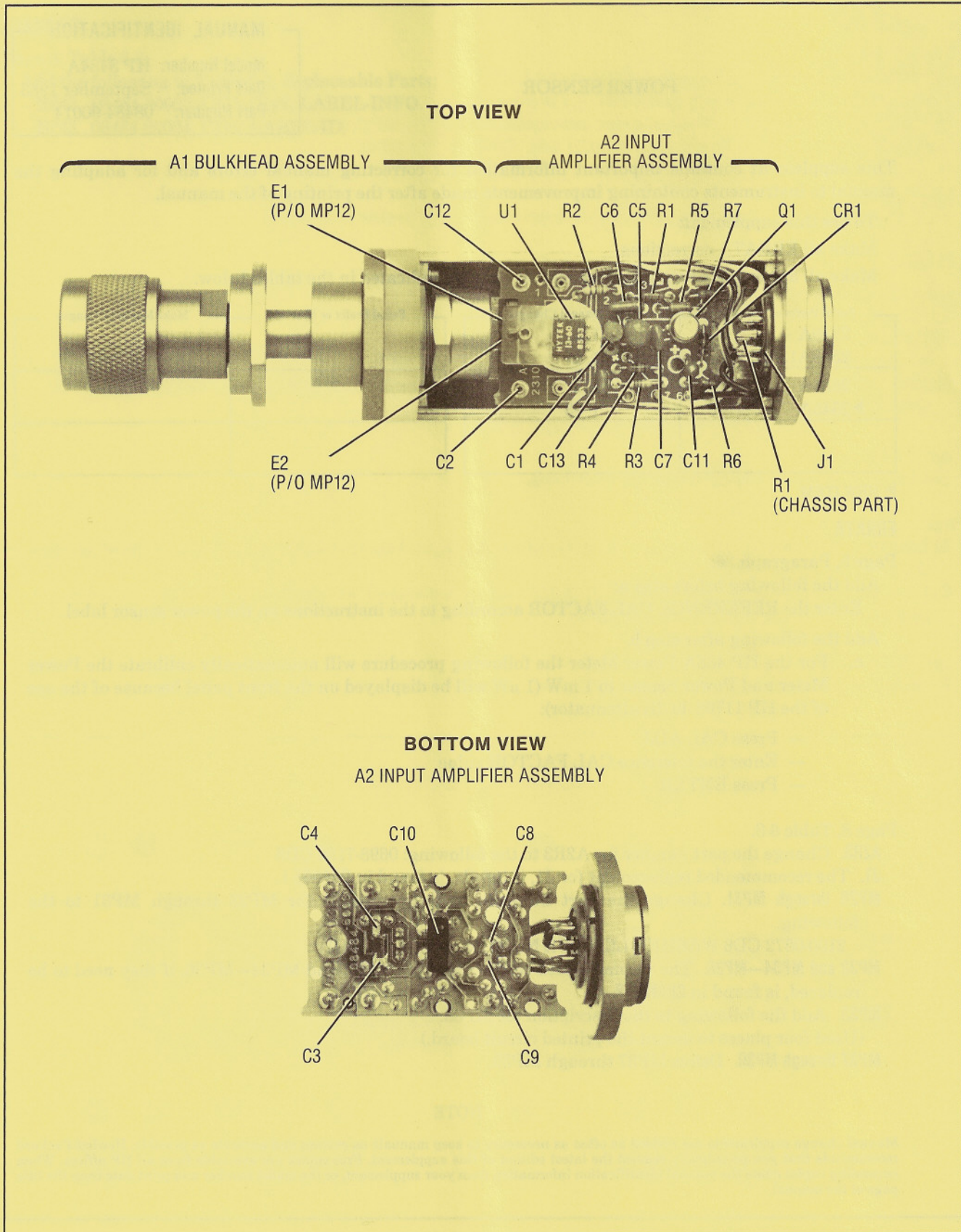

Figure 4. Component and Assembly Locations (P/O CHANGE 2)

CHANGE 1

Page 8, Table 6-3:

J1. Change the part number for J1 to 08481-60024 CD7.

Add the following to the description for J1: (J1 includes the wires that are soldered to the printed circuit board.)

MP16—MP22. Change the part number and description for MP16—MP22 to the following:

MP16-MP22 0520-0166 CD3 SCREW-MACH 2-56 .375-IN-LG 82 DEG.

Page 11, Figure 5:

At J1 (right side of schematic) remove the line connecting pin A to pins F, M and J.

CHANGE 2

Page 8, Table 6-3:

A2. Change the part number for A2 to the following: 08484-60031 CD9.

A2C12. After A2C12 add the following:

A2C13 0160-0576 CD5 CAPACITOR-FXD .1 μ F \pm 20% 50 VDC CER.

MP32 and MP34—MP36. Change the part number and description for MP32 and MP34—MP36 to the following:

3030-0954 CD1 SCREW-SKT HD CAP 0-80 .188-IN-LG SST-304.

Page 10, Figure 4:

Replace Figure 4 with Figure 4 in this supplement.

Page 11, Figure 5:

A2 Input Amplifier Assembly. In the upper left corner of the A2 Input Amplifier Assembly schematic drawing, change the part number to 08484-60031.

C13. On the A2 assembly below "INPUT GUARD" (left side of assembly), add C13 (.1 μ F) between the line connected to U1 pin 5 and chassis ground.

Page 15, Figure 7:

Replace the portion of Figure 7 with the portion of Figure 7 below.

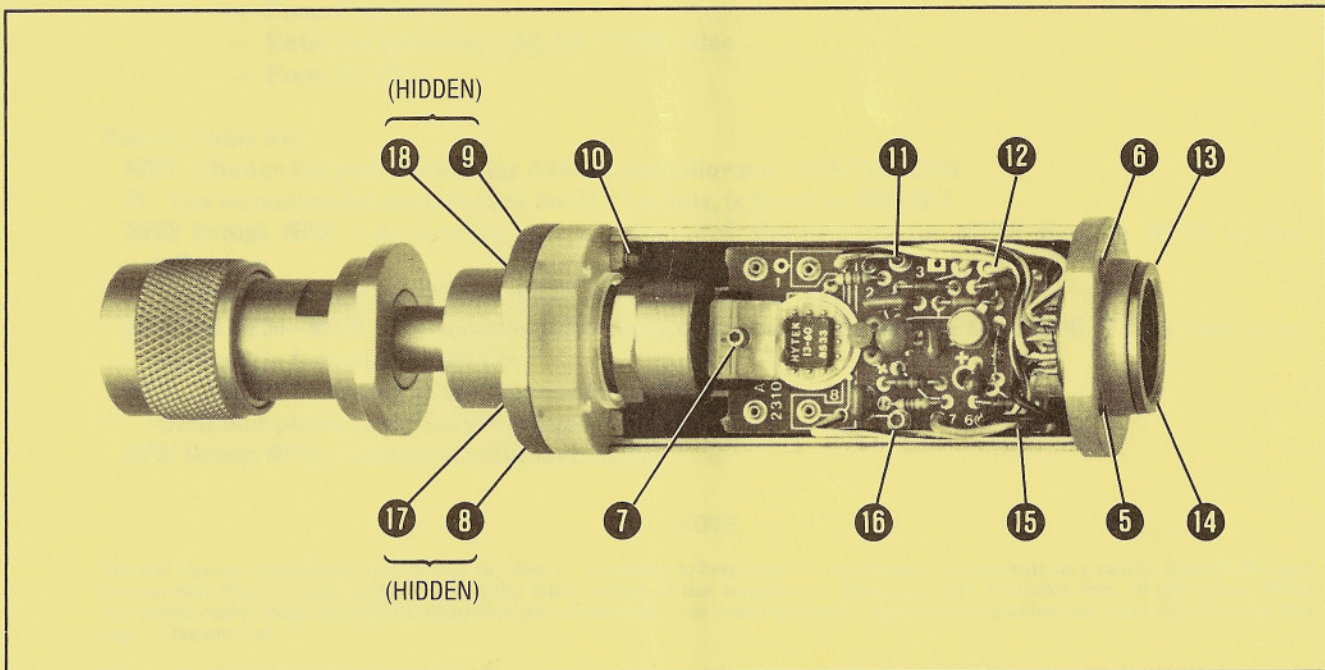

P/O Figure 7. Power Sensor Disassembly and Assembly (P/O CHANGE 2)

►CHANGE 3

Page 8, Table 6-3:

Add the following to Table 6-3, Replaceable Parts:

MP42. 08484-80003, CD7, Qty2, LABEL-INFO.

MP43. 08484-80004, CD8, LABEL-ID.



